

Project no: TREN/07/FP6EN/S07.73164/038533 /CONS

Project acronym: ADINE

Project title: Active Distribution Network

Deliverable D23: Real-time simulation results report

Due date of deliverable: 31.03.2009

Actual submission date: 02.04.2009

Start date of project: 1.10.2007

Duration: 36 months

Organisation name of lead contractor for this deliverable: Tampere University of Technology

Revision [1.0]

| | | |
|---|---|---|
| Project co-funded by the European Commission within the Sixth Framework Programme (2002-2006) | | |
| Dissemination level | | |
| PU | Public | X |
| PP | Restricted to other programme participants (including the Commission Services) | |
| RE | Restricted to a group specified by the consortium (including the Commission Services) | |
| CO | Confidential, only for members of the consortium (including the Commission Services) | |

TABLE OF CONTENTS:

1. INTRODUCTION 3

2. REAL TIME SIMULATION MODEL..... 4

3. THE SIMULATION RESULTS..... 8

4. CONCLUSIONS 13

1. Introduction

The development of control system has proceeded faster than planned in the project schedule. Real time simulations were done a lot earlier but for other type of compensation environment than is was planned for the demo case.

The environment for simulation already done previously is requiring similar functionalities from a STATCOM than a network management system does. Therefore the same control strategies can be applied in both cases.

As the requirements of STATCON for the ADINE STATCOM demo case are not yet specified, it is not possible at this stage do some target specific real time simulations. This document is referring to real time simulations done using the controller with a model of an electric arc furnace (EAF) application

2. Real time simulation model

Real time simulations are done using RTDS™ simulator based on RSCAD software. The following pictures are describing the simulation network model.

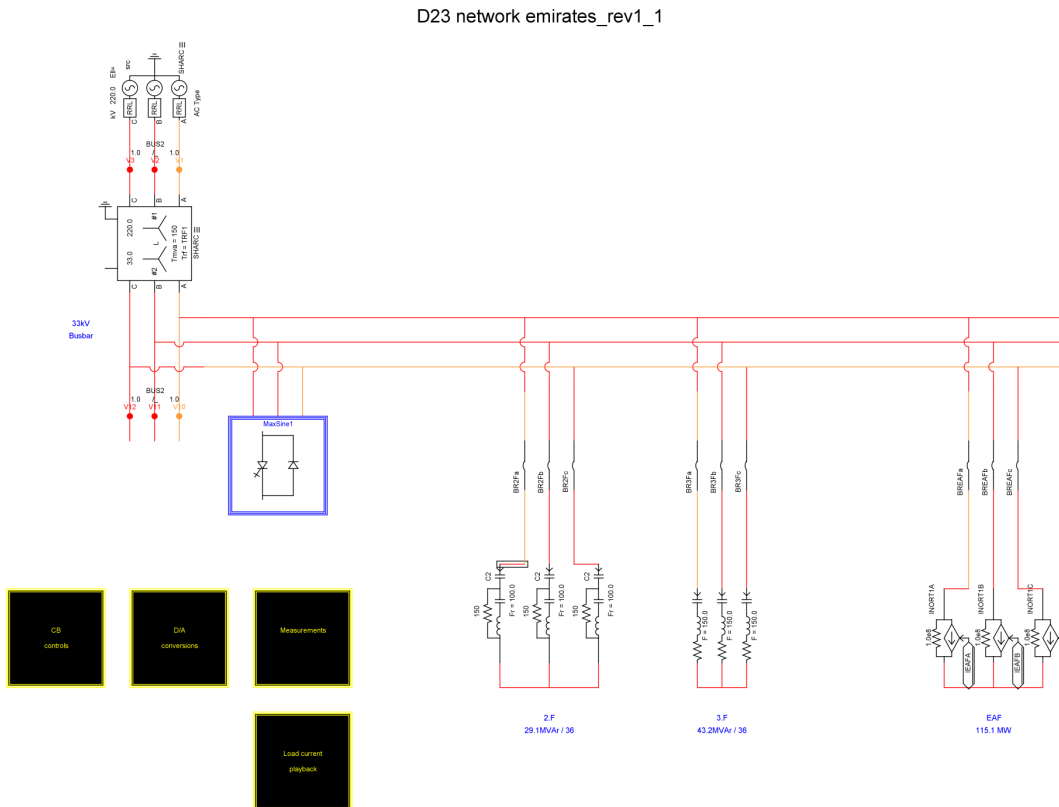

Picture 1. Simulated network model.

The network consists of high voltage (220 kV) transmission line, 220/33 kV step down transformer, 33 kV busbar (distribution), 2nd and 3rd harmonic filters and a static compensator (STATCOM).

EAF represents the load which is actually an adjustable current generator. Pre-recorded “real life” currents are injected to the simulation giving reality to the results. Amplification of the injection can be altered and different degrees of compensation can thus be compared.

Current and voltage waveforms can be taken out from the simulation by D/A converters. Power quality can be analysed from the analogue output signals using ordinary analysers.

Also the STATCOM is using the signals for controlling the IGBT bridge.

The main network is running at 50us time cycles and is thus updated 20000 times/s. The converter is included in so called small time step block. As the switching frequency of the IGBT’s is in the range of 1.2 kHz, the block must be updated faster - in the range of 2 us time steps.

D23 network emirates_rev1_1

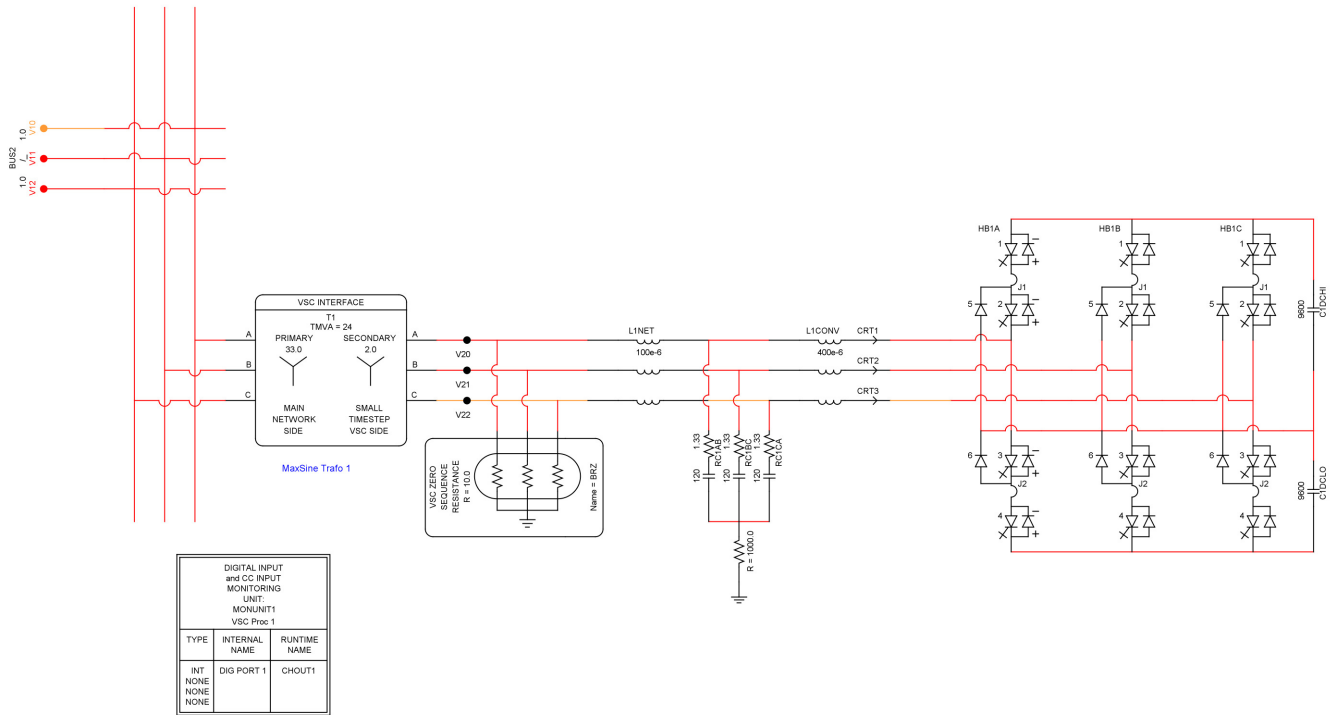

Picture 2. “Small time-step-part” of the simulation model.

The “small time-step-part” of the simulation model shown in Picture 2, includes besides the IGBT bridge, a ripple filter and 33/2 kV transformer. The IGBT bridge is rated to 2 kV nominal voltage.

The black box in the main page includes definitions of data conversions, calculations, controls etc.

An alternative method to use recorded data for the simulation is to transfer it digitally via Ethernet from a computer. If the length of the record is reasonable, the digital playback is preferable (Picture 3.).

Data playback emirates_rev1_1

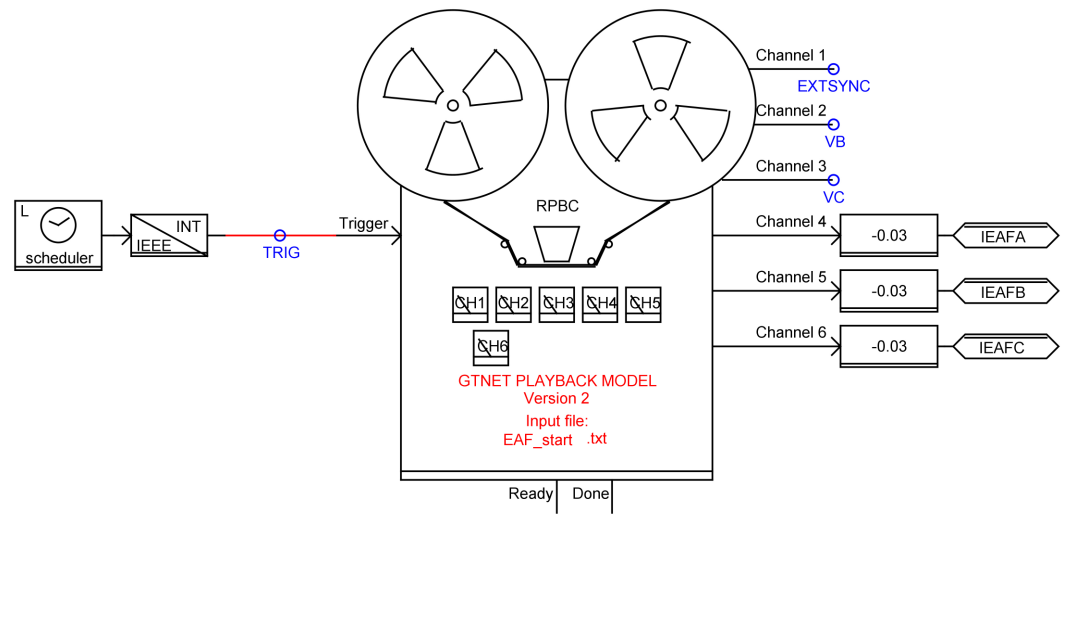

Picture 3. Digital playback method of recorded data.

The STATCOM is controlled in this simulation case by open and closed loop control. The open loop is compensating reactive power of the load, harmonics and flicker. The closed loop is compensating the PCC (point of common coupling) reactive power or keeping the voltage stable, whichever is selected.

Data playback emirates_rev1_1

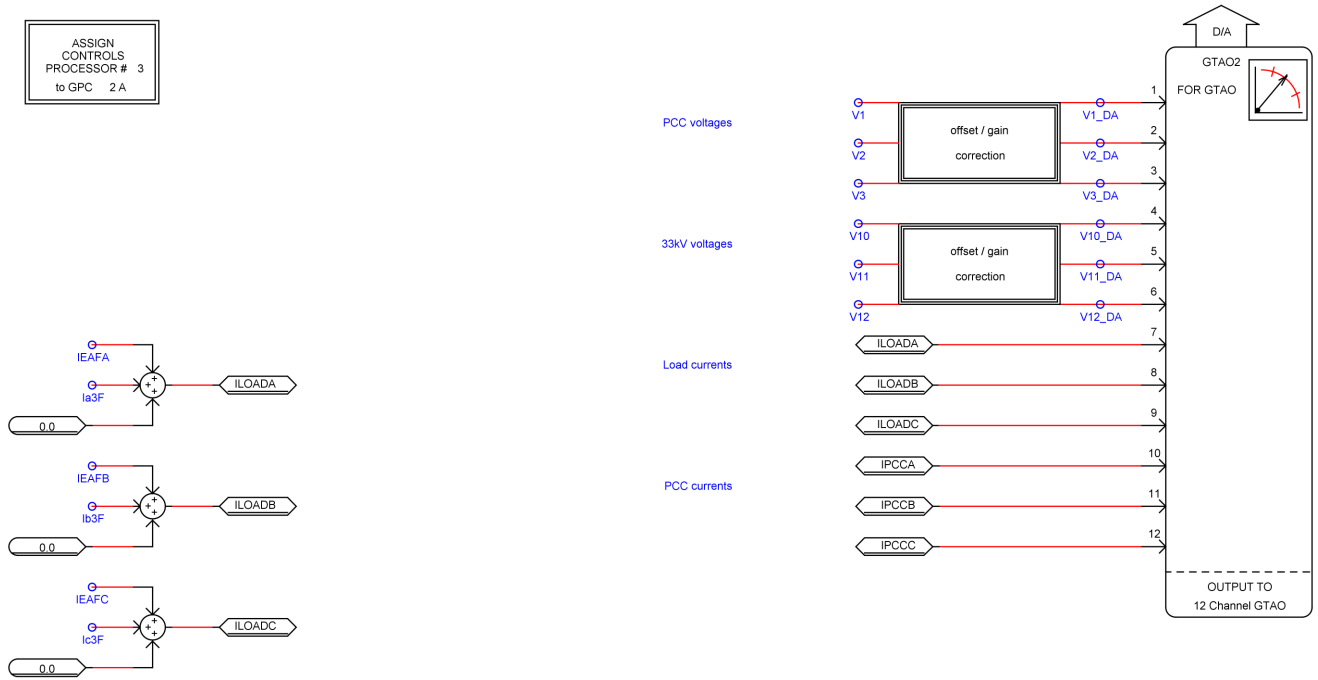

Picture 4. Measurements from the simulation to the STATCOM controller.

3. The simulation results

The phase currents from electric arc furnace (EAF) shown in Picture 5 were used for simulation as load. Phase L1 voltage was used for synchronizing the signals to correct phase angle. The following signals show typical worst case load currents of an EAF. Unbalance (negative sequence components) is very high. Also the current harmonics are high, causing voltage harmonics in a weak network if not compensated.

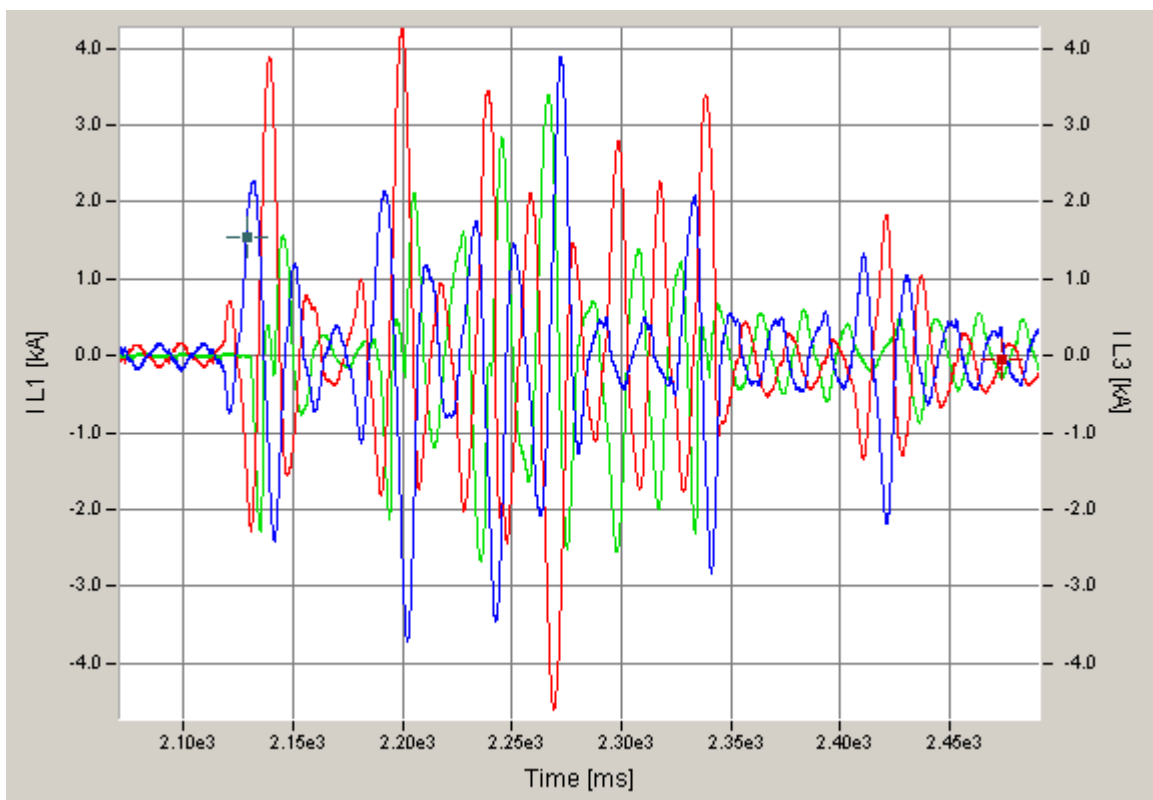

Picture 5. EAF current waveforms.

Simulations were done by running the data with and without active compensation. The quality of the compensation could be verified by comparing the power quality measurement results. Fluke 434 power quality analyzer was used for the measurements.

Flicker reduction:

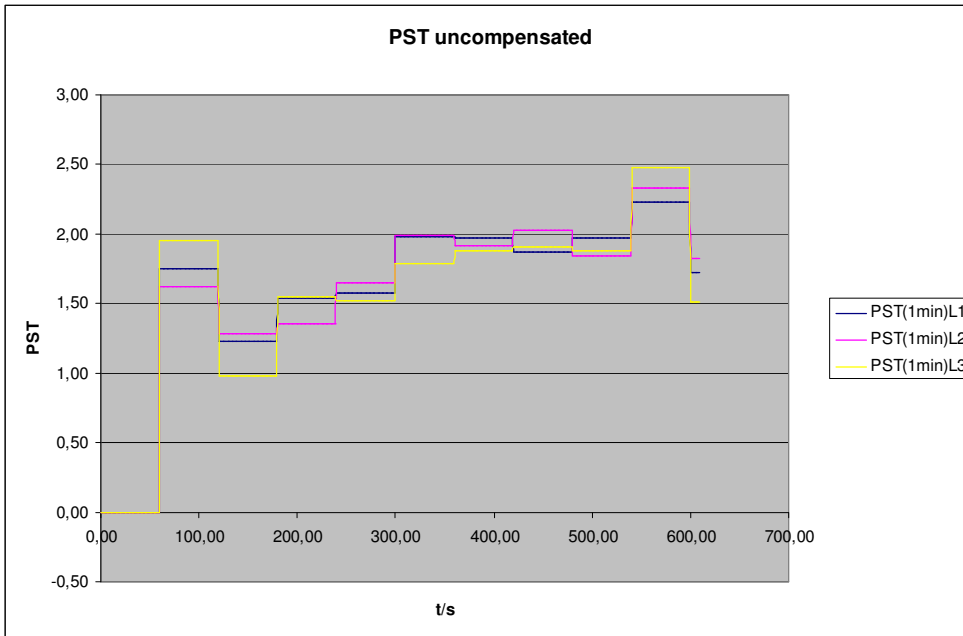

Picture 6. Flicker Pst value without compensation

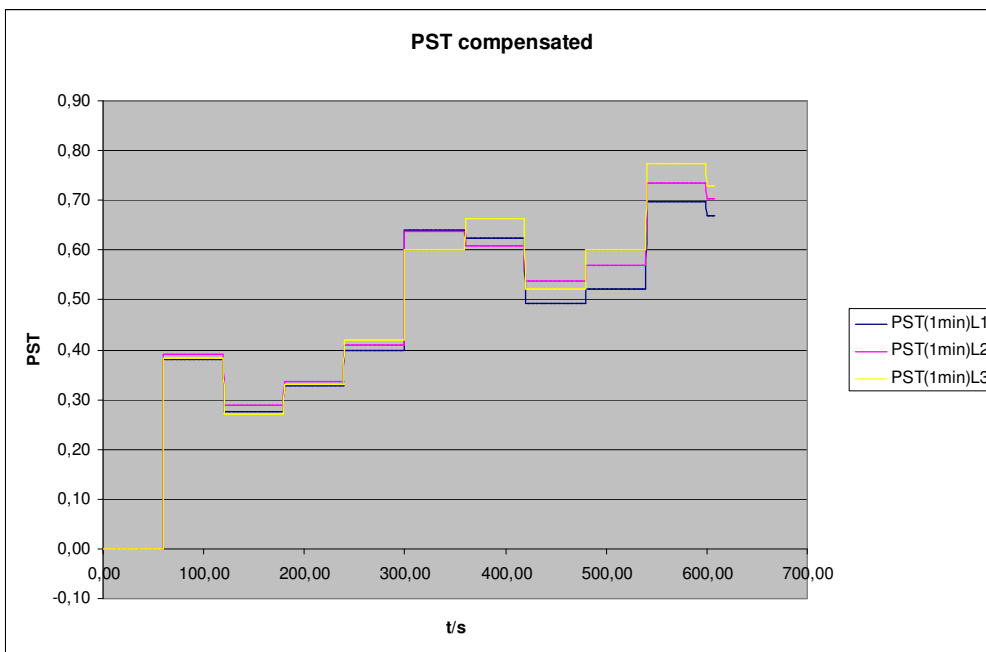

Picture 7. Pst values with compensation

Harmonic distortion

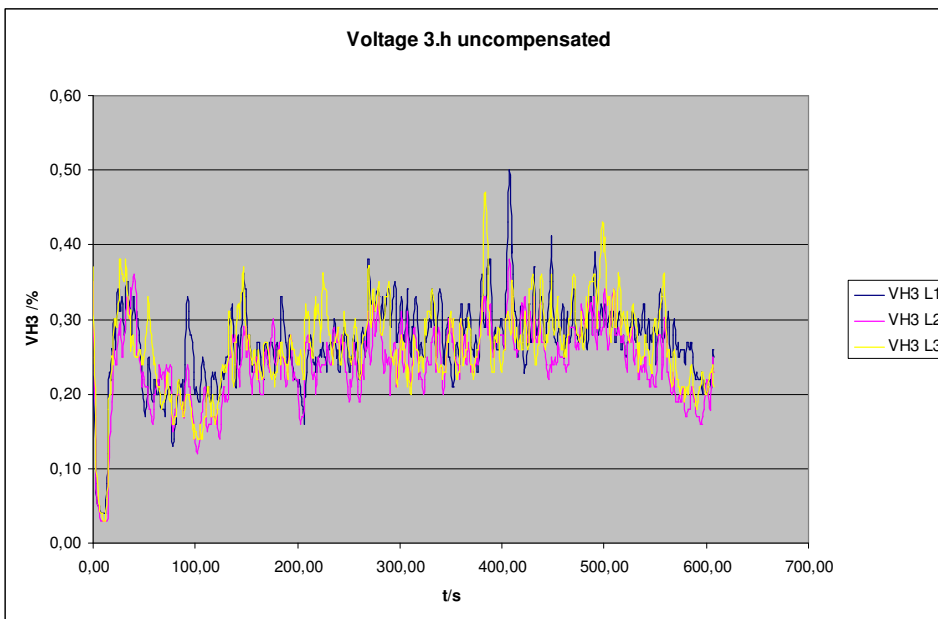

Picture 8. 3rd Harmonic voltage distortion

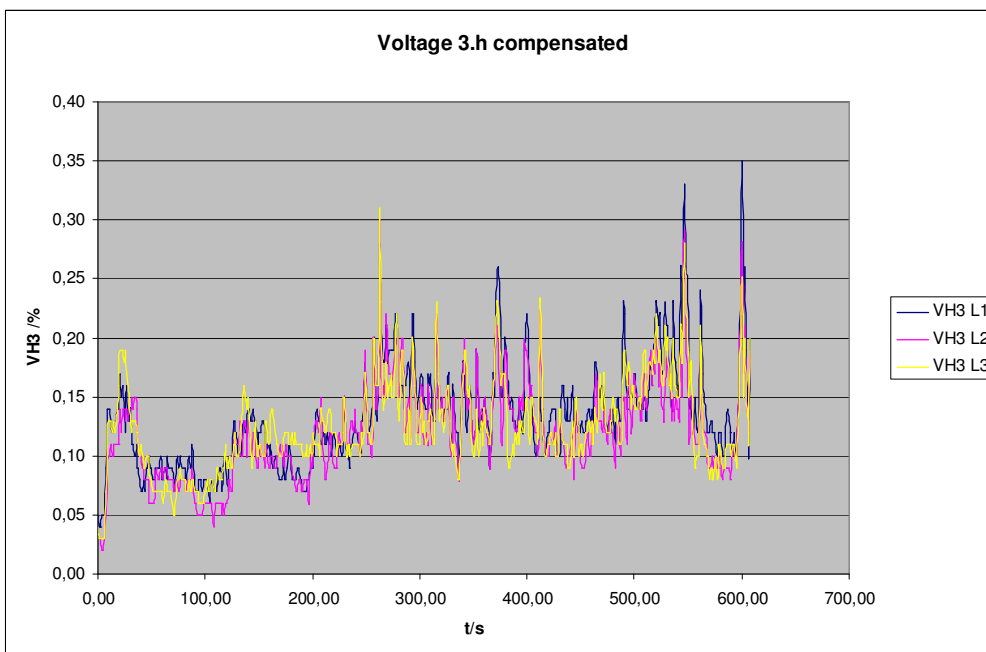

Picture 9. 3rd harmonic voltage distortion with compensation

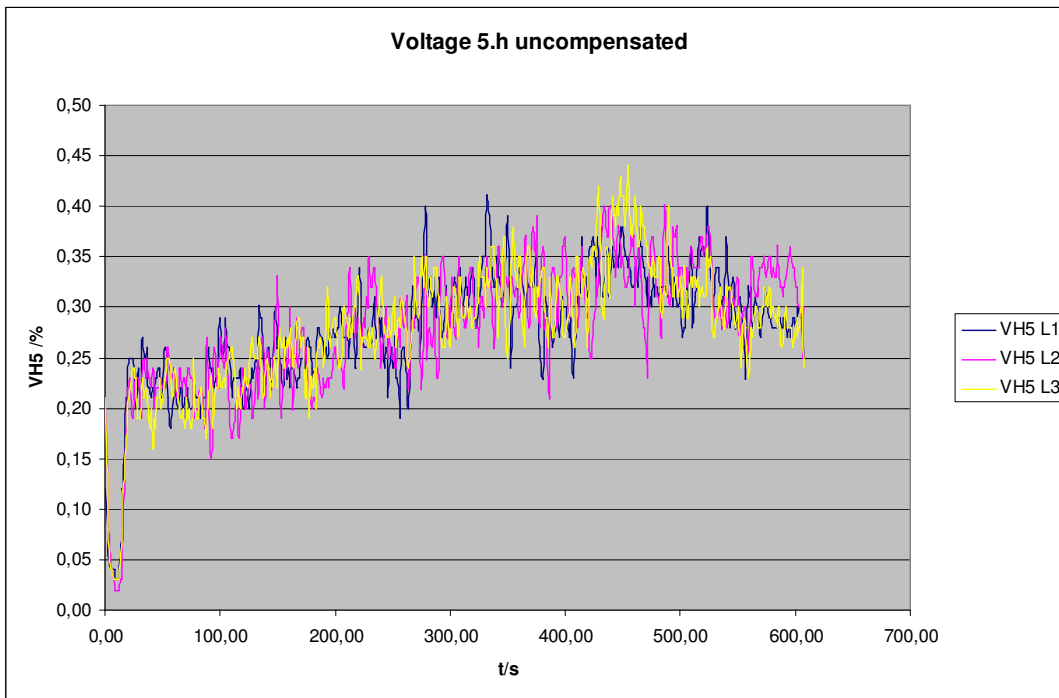

Picture 10. 5th Harmonic voltage distortion without compensation

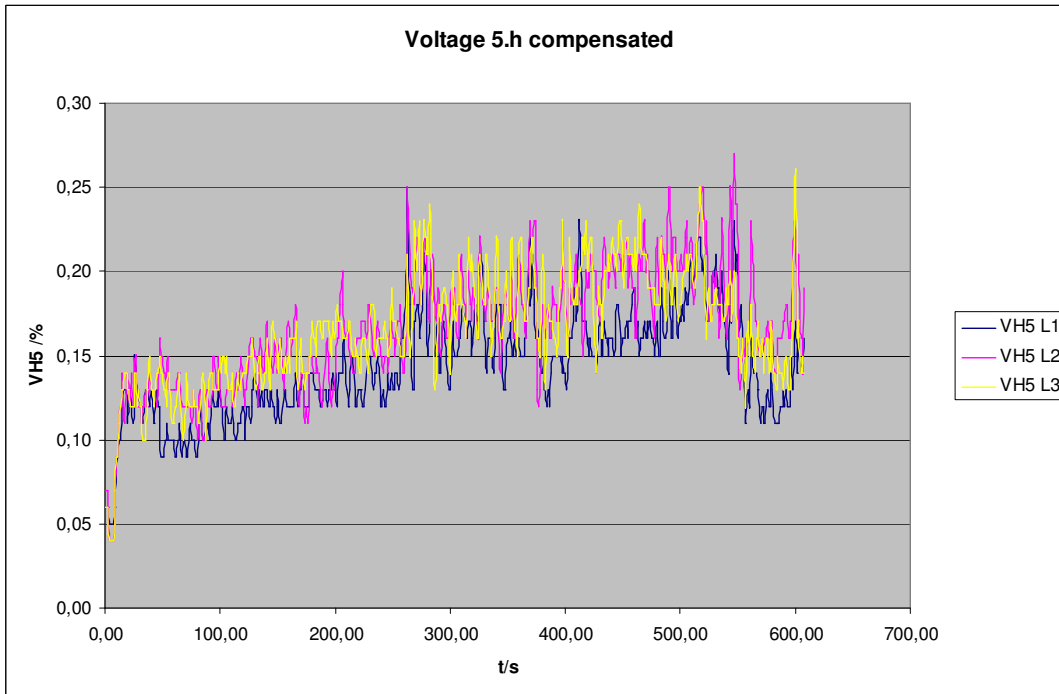

Picture 11. 5th Harmonic voltage distortion with compensation

Unbalance

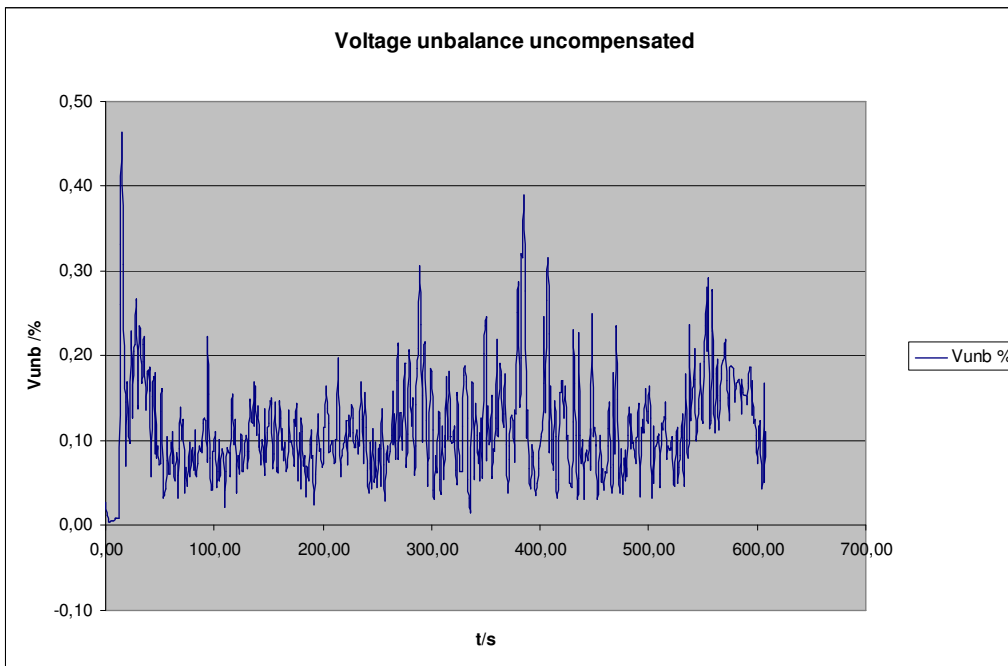

Picture 12. Non compensated voltage unbalance

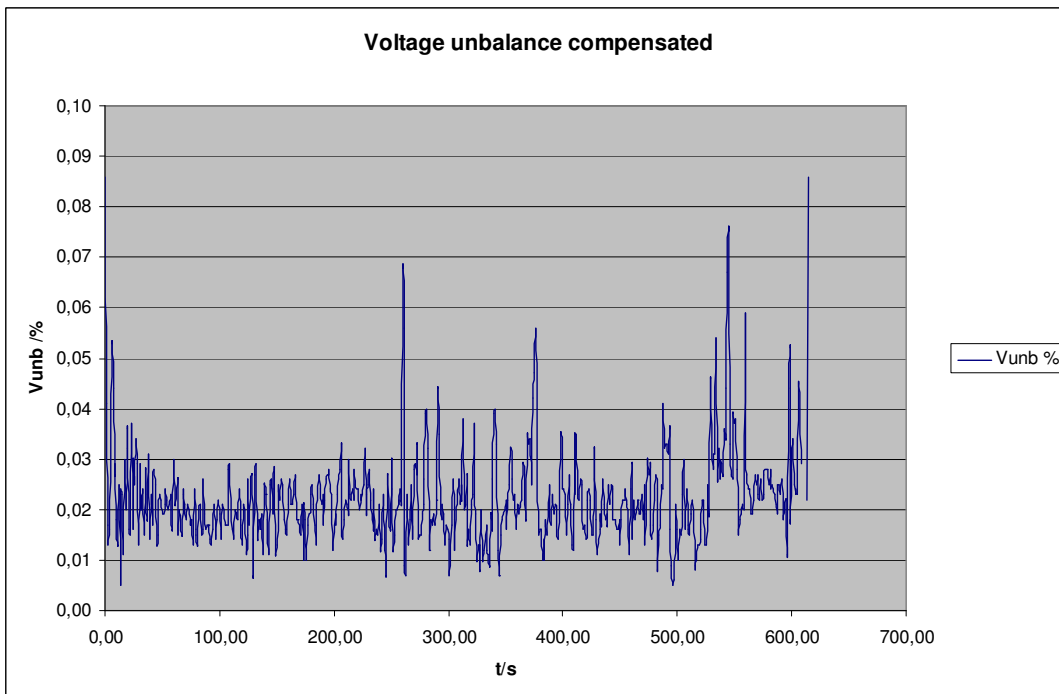

Picture 13. Compensated voltage unbalance

4. Conclusions

The simulations were done in purpose to verify the performance of the control system. However the performance depends very much on the STATCOM hardware to be controlled and its dimensioning.

The controller was operated with similar hardware in real environment as in simulation. The control software was however changed. The results of tests in real environment showed that the performance was the same or better compared to simulation results. It also appeared that compensating a load shown in picture 5 requires strengthened DC link.

Real time simulations are continued as soon as the demo site requirements are specified.